



Europäisches Patentamt
European Patent Office
Office européen des brevets



(11) **EP 0 406 304 B1**

(12) **EUROPEAN PATENT SPECIFICATION**

(45) Date of publication and mention
of the grant of the patent:
20.08.1997 Bulletin 1997/34

(51) Int Cl.⁶: **C12Q 1/00, C12Q 1/26,
C12M 1/34, G01N 27/26**

(21) Application number: **89904316.0**

(86) International application number:
PCT/US89/01057

(22) Date of filing: **14.03.1989**

(87) International publication number:
WO 89/08713 (21.09.1989 Gazette 1989/23)

(54) **METHOD AND APPARATUS FOR AMPEROMETRIC DIAGNOSTIC ANALYSIS**

VERFAHREN UND VORRICHTUNG ZUR AMPEROMETRISCHEN DIAGNOSTISCHEN ANALYSE

PROCEDE ET APPAREIL D'ANALYSE DIAGNOSTIQUE AMPEROMETRIQUE

(84) Designated Contracting States:
AT BE CH DE FR GB IT LI LU NL SE

(74) Representative: **Allam, Peter Clerk et al
LLOYD WISE, TREGEAR & CO.,
Commonwealth House,
1-19 New Oxford Street
London WC1A 1LW (GB)**

(30) Priority: **15.03.1988 US 168295
13.03.1989 US 322598**

(43) Date of publication of application:
09.01.1991 Bulletin 1991/02

(56) References cited:

EP-A- 0 256 806	GB-A- 2 201 248
US-A- 3 838 033	US-A- 3 925 183
US-A- 4 005 002	US-A- 4 040 908
US-A- 4 169 779	US-A- 4 217 196
US-A- 4 225 410	US-A- 4 682 602
US-A- 4 796 014	

(73) Proprietor: **TALL OAK VENTURES
Allison Park Pennsylvania 15101 (US)**

(72) Inventors:

- **POTTGEN, Paul, A.
Allison Park, PA 15101 (US)**
- **SZUMINSKY, Neil, J.
Pittsburgh, PA 15216 (US)**
- **TALBOTT, Jonathan, L.
Mars, PA 16046 (US)**
- **JORDAN, Joseph
State College, PA 16803 (US)**

• **MICROCHEMICAL JOURNAL, Vol. 37, February
1988, pages 5 to 12; J.Talbott, J. Jordan "A new
Microchemical Approach to Amperometric
Analysis"**

Note: Within nine months from the publication of the mention of the grant of the European patent, any person may give notice to the European Patent Office of opposition to the European patent granted. Notice of opposition shall be filed in a written reasoned statement. It shall not be deemed to have been filed until the opposition fee has been paid. (Art. 99(1) European Patent Convention).

EP 0 406 304 B1

Description

FIELD OF THE INVENTION:

5 The present invention relates to a disposable electroanalytical cell and a method and apparatus for quantitatively determining the presence of biologically important compounds such as glucose; TSH; T4; hormones such as HCG; cardiac glycosides such as Digoxin; antiarrhythmics such as Lidocaine; antiepileptics such as phenobarbital; antibiotics such as Gentamicin; cholesterol; non-therapeutic drugs and the like from body fluids.

10 Although the present invention has broad applications, for purposes of illustration of the invention specific emphasis will be placed upon its application in quantitatively determining the presence of two biologically important compounds -- glucose and cholesterol.

WITH RESPECT TO GLUCOSE:

15 Diabetes, and specifically diabetes mellitus, is a metabolic disease characterized by deficient insulin production by the pancreas which results in abnormal levels of blood glucose. Although this disease afflicts only approximately 4% of the population in the United States, it is the third leading cause of death following heart disease and cancer. With proper maintenance of the patient's blood sugar through daily injections of insulin, and strict control of dietary intake, the prognosis for diabetics is excellent. However, the blood glucose levels must be closely followed in the patient
20 either by clinical laboratory analysis or by daily analyses which the patient can conduct using relatively simple, non-technical, methods.

At the present, current technology for monitoring blood glucose is based upon visual or instrumental determination of color change produced by enzymatic reactions on a dry reagent pad on a small plastic strip. These colorimetric methods which utilize the natural oxidant of glucose to gluconic acid, specifically oxygen, are based upon the reactions:
25

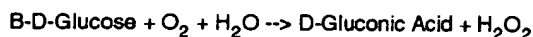
WITH RESPECT TO CHOLESTEROL:

35 Current technology for the determination of cholesterol is also based upon similar methods. In the case of cholesterol, the methods presently used are based upon the generalized reactions:

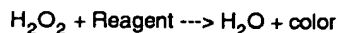
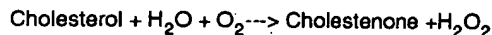

45 In all present techniques, Dioxygen is the only direct oxidant used with the enzyme cholesterol oxidase for the determination of both free and total cholesterol. Using conventional test methods, oxygen must diffuse into the sensor solution during use from the surrounding air in order to provide sufficient reagent for a complete reaction with the analyte cholesterol in undiluted serum and whole blood specimens.

In both instances, the presence of the substance is determined by quantifying, either colorimetrically or otherwise, the presence of hydrogen peroxide. The present methods of detection may include direct measurement of the hydrogen peroxide produced by either spectroscopic or electrochemical means and indirect methods in which the hydrogen peroxide is reacted with various dyes, in the presence of the enzyme peroxidase, to produce a color that is monitored.
50

While relatively easy to use, these tests require consistent user technique in order to yield reproducible results. For example, these tests require the removal of blood from a reagent pad at specified and critical time intervals. After the time interval, excess blood must be removed by washing and blotting, or by blotting alone, since the color measurement is taken at the top surface of the reagent pad. Color development is either read immediately or after a specified
55 time interval.

These steps are dependent upon good and consistent operating technique requiring strict attention to timing. Moreover, even utilizing good operating technique, colorimetric methods for determining glucose, for example, have been shown to have poor precision and accuracy, particularly in the hypoglycemic range. Furthermore, instruments used for

the quantitative colorimetric measurement vary widely in their calibration methods: some provide no user calibration while others provide secondary standards.

US-A-4040908 discloses a method for determining the amount of macromolecular substances, such as cholesterol, in a material under analysis. The method utilises enzymes for the conversion of such macromolecular substances to produce ultimately hydrogen peroxide and measures the hydrogen peroxide generated with a membrane covered polarographic anode. Specifically, the macromolecular substance under analysis enters into an enzymatic reaction in a sample chamber on the side of the membrane opposite the anode and the membrane, which is impermeable to such macromolecular substances, senses the hydrogen peroxide generated because at least a portion of the hydrogen peroxide diffuses into the membrane into contact with the electrode. The current flowing across the cell can then be determined as a measure of the rate of formation of the hydrogen peroxide and as an indication of the amount of macromolecular substances in the material under analysis.

US-A-4005002 discloses a method for measuring the concentration of substrates of enzyme reactions, such as lactate and glucose, in biological fluids in which a current produced at a platinum or gold electrode by oxidising an acceptor is measured by a measuring device comprising a measuring cell for receiving the fluid sample, an enzyme electrode in contact with the test solution and containing a platinum or gold electrode, an enzyme layer and a semi-permeable membrane covering the enzyme layer, and a reference electrode in contact with the fluid sample.

US-A-4225410 discloses a disposable integrated miniaturised array of chemical sensors for analysing concurrently a number of analytes in a fluid sample. Each sensor is a complete electrochemical cell consisting of its own individual reference and indicator electrodes and is selective with respect to a particular analyte in the sample.

US-A-3925183 discloses a gas detecting and measuring unit comprising in combination intake means, a gas sample reservoir, an electrochemical cell, means for drawing a gas through the intake means and into the electrochemical cell at a controlled flow rate, and read out means for reading the quantity of detected gas. The gas sample reservoir and the electrochemical cell, at least, are in heat communication with a heat reservoir for providing constant temperature for at least one hour without requiring additional heat energy input, the heat reservoir comprising a high latent heat of fusion material adapted to be heated to at least its melting point prior to use. The electrochemical cell comprises an anode which will catalyse an electrochemical reaction with alcohol gas to be detected within the potential range where oxygen reduction or oxidation of water to oxygen does not occur, a cathode, a reference electrode, and an aqueous electrolyte in contact with the anode, cathode and reference electrode, the anode being adapted to be maintained at a fixed potential relative to the reference electrode.

US-A-4169779 discloses an electrochemical cell for the detection of hydrogen sulphide which includes a gold working electrode and a counter electrode, with or without a reference electrode, comprising either gold or platinum black which operate in a substantially non-aqueous electrolyte consisting preferably of lithium perchlorate dissolved in an organic solvent selected from γ -butyrolactone and propylene carbonate. A fixed potential is maintained between the working electrode and a reference air electrode.

Microchemical Journal, Vol. 37, February 1988, pp.5-12 discloses an enzymatic amperometry method for determining the quantity of glucose in an aqueous glucose solution. The method utilises a binary reaction sequence in which, in the first reaction, β -D-glucose is selectively oxidised with benzoquinone in the presence of the enzyme glucose oxidase to produce gluconic acid and hydroquinone and, in the second reaction, equivalent amounts of benzoquinone are reduced to hydroquinone thereby enabling quantification of the hydroquinone produced in the first reaction. However, no tests were carried out on biological fluids and it is apparent from the discussion on page 11 that the authors envisaged that practical implementation of this method for glucose self-monitoring by diabetics may be handicapped by ancillary difficulties such as volatility of the reagent benzoquinone.

Because of the general lack of precision and standardization of the various methods and apparatus presently available to test for biologically important compounds in body fluids, some physicians are hesitant to use such equipment for monitoring levels or dosage. They are particularly hesitant in recommending such methods for use by the patients themselves. Accordingly, it is desirable to have a method and apparatus which will permit not only physician but patient self-testing of such compounds with greater reliability.

The present invention addresses the concerns of the physician by providing enzymatic amperometry methods and apparatus for monitoring compounds within whole blood, serum, and other body fluids. Enzymatic amperometry provides several advantages for controlling or eliminating operator dependant techniques as well as providing a greater linear dynamic range. A system based on this type of method could address the concerns of the physician hesitant to recommend self-testing for his patients.

Enzymatic amperometry methods have been applied to the laboratory based measurement of a number of analytes including glucose, blood urea nitrogen, and lactate. Traditionally the electrodes in these systems consist of bulk metal wires, cylinders or disks imbedded in an insulating material. The fabrication process results in individualistic characteristics for each electrode necessitating calibration of each sensor. These electrodes are also too costly for disposable use, necessitating meticulous attention to electrode maintenance for continued reliable use. This maintenance is not likely to be performed properly by untrained personnel (such as patients), therefore to be successful, an enzyme am-

perometry method intended for self-testing (or non-traditional site testing) must be based on a disposable sensor that can be produced in a manner that allows it to give reproducible output from sensor to sensor and at a cost well below that of traditional electrodes.

The present invention addresses these requirements by providing miniaturized disposable electroanalytic sample cells for precise micro-aliquot sampling, a self-contained, automatic means for measuring the electrochemical reduction of the sample, and a method for using the cell and apparatus according to the present invention.

According to the present invention there is therefore provided a method for measuring the amount of a selected compound in body fluids comprising,

- a) providing a measuring cell having a first and second electrode and said cell containing an oxidant and a buffer,
- b) placing a sample of fluid to be tested in said cell,
- c) reconstituting said oxidant and buffer with said sample fluid to generate a predetermined catalyzed reaction,
- d) allowing said reaction to proceed substantially to completion,
- e) applying a potential across said electrodes and sample and,
- f) measuring the resultant Cottrell current to determine the concentration of said selected compound present in said sample,

wherein the placing of the sample of fluid to be tested in said cell in step (b) causes a charging current to flow which is detected and begins a reaction incubation step to allow the predetermined catalysed reaction substantially to reach completion and then causes a potential to be applied across said electrodes and causes the Cottrell current to be measured at specific time points during the Cottrell current decay.

The selected compound is preferably selected from glucose, cholesterol, TSH, T4, hormones, antiarrhythmics, antiepileptics, and nontherapeutic drugs.

According to the present invention there is also provided a sample cell for determining the concentration of a selected compound in a sample body fluid, comprising,

- a) a metallized first electrode which acts as a working electrode,
- b) a metallized second electrode which acts as a reference electrode or a pseudo reference electrode, said second electrode being operatively associated with said first electrode;
- c) at least one non-conducting layer member having an opening therethrough, said non-conducting layer member being disposed in contact with at least one of said electrodes and said non-conducting layer member being sealed against at least one of said first and second electrodes to form a known electrode area within said opening such that said opening forms a well to receive said sample body fluid and to allow placement of said fluid in said known electrode area in contact with said first electrode and second electrode, said cell also including a reagent layer positioned within said well created by said opening wherein said reagent layer contains an oxidant, a buffer, and a binding agent, whereby the contents of said well are capable of being subjected to a predetermined catalyzed reaction;
- d) means for applying a potential across said electrodes after said predetermined catalyzed reaction has proceeded substantially to completion; and
- e) means for measuring the resulting Cottrell current following application of said potential; wherein that the cell also comprises means for causing a charging current to flow upon placement of said fluid in said known electrode area to detect the presence of said fluid, which begins a reaction incubation step to allow the predetermined catalysed reaction substantially to reach completion and which then causes a potential to be applied across said electrodes by said means (d) and causes the Cottrell current to be measured at specific time points during the Cottrell current decay by said means (e).

According to the present invention there is further provided an apparatus for measuring compounds in a sample body fluid, comprising:

- a. a housing having an access opening therethrough,
- b. a sample cell receivable into said access opening of said housing, said sample cell being as defined above,
- c. means for creating an electrical circuit between said first electrode and said second electrode through said sample body fluid, and
- d. means for visually displaying a measurement of said sample body fluid made by said apparatus,

wherein that the apparatus also comprises means for initiating an electrical potential upon insertion of said sample cell to detect the presence of said sample body fluid, said initiating means also having means for removing said potential once the sample body fluid has been detected.

The disposable cells according to the present invention are preferably laminated layers of metallized plastic and nonconducting material. The metallized layers provide the working and reference electrodes, the areas of which are reproducibly defined by the lamination process. An opening through these layers is designed to provide the sample-containing area or cell for the precise measurement of the sample. The insertion of the cell into the apparatus according to the present invention, automatically initiates the measurement cycle.

To better understand the process of measurement, a presently preferred embodiment of the invention is described which involves a two-step reaction sequence utilizing a chemical oxidation step using other oxidants than oxygen, and an electro-chemical reduction step suitable for quantifying the reaction product of the first step. One advantage to utilizing an oxidant other than dioxygen for the direct determination of an analyte is that they may be prepositioned in the sensor in a large excess of the analyte and thus ensure that the oxidant is not the limiting reagent (with dioxygen, there is normally insufficient oxidant initially present in the sensor solution for a quantitative conversation of the analyte).

In the oxidation reaction, a sample containing glucose, for example, is converted to gluconic acid and a reduction product of the oxidant. This chemical oxidation reaction has been found to proceed to completion in the presence of an enzyme, glucose oxidase, which is highly specific for the substrate B-D-glucose, and catalyzes oxidations with single and double electron acceptors. It has been found, however, that the oxidation process does not proceed beyond the formation of gluconic acid, thus making this reaction particularly suited for the electrochemical measurement of glucose.

In a presently preferred embodiment, oxidations with one electron acceptor using ferricyanide, ferricinium, cobalt (III) orthophenanthroline, and cobalt (III) dipyriddy are preferred. Benzoquinone is a two electron acceptor which also provides excellent electro-oxidation characteristics for amperometric quantitation.

Amperometric determination of glucose, for example, in accordance with the present invention utilizes Cottrell current micro-chronoamperometry in which glucose plus an oxidized electron acceptor produces gluconic acid and a reduced acceptor. This determination involves a preceding chemical oxidation step catalyzed by a bi-substrate bi-product enzymatic mechanism as will become apparent throughout this specification.

In this method of quantification, the measurement of a diffusion controlled current at an accurately specified time (e.g. 20, 30, or 50 seconds, for example) after the instant of application of a potential has the applicable equation for amperometry at a controlled potential ($E = \text{constant}$) of:

$$i_{\text{COTTRELL}} = nFA(\pi D t)^{-0.5} \cdot C_{\text{METABOLITE}}$$

at $t > 0$ at $t = 0$

where i denotes current, nF is the number of coulombs per mole, D is the diffusion coefficient of the reduced form of the reagent, t is the preset time at which the current is measured, and C is the concentration of the metabolite. Measurements by the method according to the present invention of the current due to the reoxidation of the acceptors were found to be proportional to the glucose concentration in the sample.

The method and apparatus of the present invention permit, in preferred embodiments, direct measurements of blood glucose, cholesterol and the like. Furthermore, the sample cell according to the present invention, provides the testing of controlled volumes of blood without premeasuring. Insertion of the sampling cell into the apparatus thus permits automatic functioning and timing of the reaction allowing for patient self-testing with a very high degree of precision and accuracy.

One of many of the presently preferred embodiments of the invention for use in measuring B-D glucose is described in detail to better understand the nature and scope of the invention. In particular, the method and apparatus according to this embodiment are designed to provide clinical self-monitoring of blood glucose levels by a diabetic patient. The sample cell of the invention is used to control the sampling volume and reaction media and acts as the electrochemical sensor. In this described embodiment, benzoquinone is used as the electron acceptor.

The basic chemical binary reaction utilized by the method according to the present invention is:

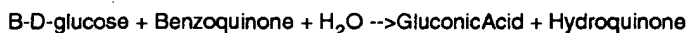

The first reaction is an oxidation reaction which proceeds to completion in the presence of the enzyme glucose oxidase. Electrochemical oxidation takes place in the second part of the reaction and provides the means for quantifying

the amount of hydroquinone produced in the oxidation reaction. This holds true whether catalytic oxidation is conducted with two-electron acceptors or one electron acceptors such as ferricyanide [wherein the redox couple would be $\text{Fe}(\text{CN})_6^{-3}/\text{Fe}(\text{CN})_6^{-4}$], ferricinium, cobalt III tris orthophenanthroline and cobalt (III) trisdipyridyl.

Catalytic oxidation by glucose oxidase is highly specific for B-D-glucose, but is nonselective as to the oxidant. It has now been discovered that the preferred oxidants described above have sufficiently positive potentials to convert substantially all of the B-D-glucose to gluconic acid. Furthermore, this system provides a means by which amounts as small as 1 mg of glucose (in the preferred embodiment) to 1000 mg of glucose can be measured per deciliter of sample - results which have not previously been obtained using other glucose self-testing systems.

The sensors containing the chemistry to perform the desired determination, constructed in accordance with the present invention, are used with a portable meter for self-testing systems. In use the sensor is inserted into the meter which turns the meter on and initiates a wait for the application of the sample. The meter recognizes sample application by the sudden charging current flow that occurs when the electrodes and the overlaying reagent layer are initially wetted by the sample fluid. Once the sample application is detected, the meter begins the reaction incubation step (the length of which is chemistry dependent) to allow the enzymatic reaction to reach completion. This period is on the order of 15 to 90 seconds for glucose, with incubation times of 20 to 45 seconds preferred. Following the incubation period, the instrument then imposes a known potential across the electrodes and measures the current at specific time points during the Cottrell current decay. Current measurements can be made in the range of 2 to 30 seconds following potential application with measurement times of 10 to 20 seconds preferred. These current values are then used to calculate the analyte concentration which is then displayed. The meter will then wait for either the user to remove the sensor or for a predetermined period before shutting itself down.

The present invention provides for a measurement system that eliminates several of the critical operator dependant variables that adversely affect the accuracy and reliability and provides for a greater dynamic range than other self-testing systems.

These and other advantages of the present invention will become apparent from a perusal of the following detailed description of one embodiment presently preferred for measuring glucose and another for measuring cholesterol which is to be taken in conjunction with the accompanying drawings in which like numerals indicate like components and in which:

FIG. 1 is an exploded view of a portable testing apparatus according to the present invention;

FIG. 2 is a plan view of the sampling cell of the present invention;

FIG. 3 is an exploded view of the sample cell shown in Figure 2;

FIG. 4 is an exploded view of another embodiment of a sample cell according to the invention;

FIG. 5 is a plan view of the cell shown in Figure 4;

FIG. 6 is still another embodiment of a sample cell;

FIG. 7 is a graph showing current as a function of glucose concentration;

FIG. 8 is a graphical presentation of Cottrell current as a function of glucose concentration; and

FIG. 9 is a presently preferred block diagram of an electrical circuit for use in the apparatus shown in Figure 1.

FIG. 10 is a preferred embodiment of the electrochemical cell.

With specific reference to Figure 1, a portable electrochemical testing apparatus 10 is shown for use in patient self-testing, such as, for example, for blood glucose levels. Apparatus 10 comprises a front and back housing 11 and 12, respectively, a front panel 13 and a circuit board 15. Front panel 13 includes graphic display panels 16 for providing information and instructions to the patient, and direct read-out of the test results. While a start button 18 is provided to initiate an analysis, it is preferred that the system begin operation when a sample cell 20 is inserted into the window 19 of the apparatus.

With reference to Figure 3, sample cell 20 is a metallized plastic substrate having a specifically-sized opening 21 which defines a volumetric well 21, when the cell is assembled, for containing a reagent pad and the blood to be analyzed. Cell 20 comprises a first 22 and second 23 substrate which may be preferable made from styrene or other substantially non-conducting plastic. Positioned on second substrate 23 is reference electrode 24. Reference electrode 24 may be preferably manufactured, for example, by vapor depositing the electrode onto a substrate made from a material such as the polyimide Kapton. In the preferred embodiment, reference electrode 24 is a silver-silver chloride electrode. This electrode can be produced by first depositing a silver chloride layer on a silver layer by either chemical or electrochemical means before the substrate is used to construct the cells. The silver chloride layer may even be generated in-situ on a silver electrode when the reagent layer contains certain of the oxidants, such as ferricyanide, and chloride as shown in the following reactions:

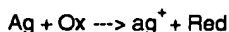

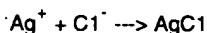

Alternatively the silver-silver chloride electrode can be produced by depositing a layer of silver oxide (by reactive sputtering) onto the silver film. This silver oxide layer is then converted in-situ at the time of testing to silver chloride according to the reaction:

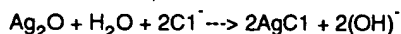

when the sensor is wetted by the sample fluid and reconstitutes the chloride containing reagent layer. The silver electrode with a layer containing silver chloride:

The reference electrode may also be of the type generally known as a "pseudo" reference electrode which relies upon the large excess of the oxidizing species to establish a known potential at a noble metal electrode. In a preferred embodiment, two electrodes of the same noble metal are used, however one is generally of greater surface area and is used as the reference electrode. The large excess of the oxidized species and the larger surface area of the reference resists a shift of the potential of the reference electrode.

Indicator or working electrode 26 can be either a strip of platinum, gold, palladium or metallized plastic positioned on reference electrode 24 or alternately the working electrode 26 and the reference electrode may be manufactured as a coplanar unit with electrode 26 being sandwiched between coplanar electrode 24 material. Preferable, sample cell 20 is prepared by sandwiching or laminating the electrodes between the substrate to form a composite unit.

As shown in Figure 2, first substrate 22 is of a slightly shorter length so as to expose an end portion 27 of electrodes 24 and 26 and allow for electrical contact with the testing circuit contained in the apparatus. In this embodiment, after a sample has been positioned within well 21, cell 20 is pushed into window 19 of the front panel to initiate testing. In this embodiment, a reagent may be applied to well 21, or, preferably, a pad of dry reagent is positioned therein and a sample (drop) of blood is placed into the well 21 containing the reagent.

Referring to Figures 4-6, alternative embodiments of sample cell 20 are shown. In Figure 4, sample cell 120 is shown having first 122 and second 123 substrates. Reference electrode 124 and working electrode 126 are laminated between substrates 122 and 123. Opening 121 is dimensioned to contain the sample for testing. End 130 is designed to be inserted into the apparatus, and electrical contact is made with the respective electrodes through cut-outs 131 and 132 on the cell. Reference electrode 124 also includes cut out 133 to permit electrical contact with working electrode 126.

In Figure 6, working electrode 226 is folded, thereby providing increased surface area around opening 221, to achieve increased sensitivity or specificity. In this case, reference electrode 224 is positioned beneath working electrode 226. Working electrode includes cut out 234 to permit electrical contact with reference electrode 224 through cut out 231 in substrate 222. End 230 of substrate 222 also includes cut out 232 to permit electrical contact with working electrode 226.

The sample cell according to the present invention is positioned through window 19 to initiate the testing procedure. Once inserted, a potential is applied at portion 27 of the sample cell across electrodes 24 and 26 to detect the presence of the sample. Once the sample's presence is detected, the potential is removed and the incubation period initiated. Optionally during this period, a vibrator means 31 may be activated to provide agitation of the reagents in order to enhance dissolution (an incubation period of 20 to 45 seconds is conveniently used for the determination of glucose and no vibration is normally required). An electrical potential is next applied at portion 27 of the sample cell to electrodes 24 and 26 and the current through the sample is measured and displayed on display 16.

To fully take advantage of the above apparatus, the needed chemistry for the self testing systems is incorporated into a dry reagent layer that is positioned onto the disposable cell creating a complete sensor for the intended analyte. The disposable electrochemical cell is constructed by the lamination of metallized plastics and nonconducting materials in such a way that there is a precisely defined working electrode area. The reagent layer is either directly coated onto the cell or preferably incorporated (coated) into a supporting matrix such as filter paper, membrane filter, woven fabric or non-woven fabric, which is then placed into the cell. When a supporting matrix is used, its pore size and void volume can be adjusted to provide the desired precision and mechanical support. In general, membrane filters or nonwoven fabrics provide the best materials for the reagent layer support. Pore sizes of 0.45 to 50um and void volumes of 50-90% are appropriate. The coating formulation generally includes a binder such as gelatin, carrageenan, methylcellulose, polyvinyl alcohol, polyvinylpyrrolidone, etc., that acts to delay the dissolution of the reagents until the reagent layer has adsorbed most of the fluid from the sample. The concentration of the binder is generally on the order of 0.1 to 10% with 1-4% preferred.

The reagent layer imbibes a fixed amount of the sample fluid when it is applied to the surface of the layer thus eliminating any need for premeasurement of sample volume. Furthermore, by virtue of measuring current flow rather

than reflected light, there is no need to remove the blood from the surface of the reagent layer prior to measurement as there is with reflectance spectroscopy systems. While the fluid sample could be applied directly to the surface of the reagent layer, to facilitate spread of blood across the entire surface of the reagent layer the sensor preferably includes a dispersing spreading or wicking layer. This layer, generally a non-woven fabric or adsorbant paper, is positioned over the reagent layer and acts to rapidly distribute the blood over the reagent layer. In some suppications this dispersing layer could incorporate additional reagents.

For glucose determination, cells utilizing the coplanar design were constructed having the reagent layer containing the following fomulations:

Glucose oxidase	600u/ml
Potassium Ferricyanide	0.4M
Phosphate Buffer	0.1M
Potassium Chloride	0.5M
Gelatin	2.0g/dl

This was produced by coating a membrane filter with a solution of the above composition and air drying. The reagent layer was then cut into strips that just fit the window opening of the cells and these strips were placed over the electrodes exposed within the windows. A wicking layer of a non-woven rayon fabric was then placed over this reagent layer and held in place with an overlay tape.

In order to prove the application of the technology according to the present invention, a large number of examples were run in aqueous solution at 25°C. The electrolyte consisted of a phosphate buffer of pH 6.8 which was about 0.1 molar total phosphate and 0.5 M potassium chloride reagent. The potentials are referenced to a normal hydrogen electrode (NHE). In these tests it was found that any potential between approximately +0.8 and 1.2 volt (vs NHE) is suitable for the quantification of hydroquinone when benzoquinone is used as the oxidant. The limiting currents are proportional to hydroquinone concentrations in the range between 0.0001 M and 0.050 M.

Determination of glucose by Cottrell current (i_t) microchronoamperometry with the present method is created in the reaction of hydroquinone to benzoquinone. Cottrell currents decay with time in accordance with the equation:

$$i_t \cdot t^{1/2} = \text{const}$$

The main difference between these two techniques consists of applying the appropriate controlled potential after the glucose-benzoquinone reaction is complete and correlating glucose concentrations with Cottrell currents measured at a fixed time thereafter. The current-time readout is shown in Figure 8. Proportionality between glucose concentrations and Cottrell currents (recorded at $t = 30$ seconds after the application of potential) is shown in Figure 7.

It should be noted that Cottrell chronoamperometry of metabolites needs the dual safeguards of enzymatic catalysis and controlled potential electrolysis. Gluconic acid yields of 99.9+ percent were attained in the presence of glucose oxidase. Concomitantly, equivalent amounts of benzoquinone were reduced to hydroquinone, which was conveniently quantitated in quiescent solutions, at stationary palladium thin film anodes or sample cells.

The results of these many tests demonstrates the microchronoamperometric methodology of the present invention and its practical for glucose self-monitoring by diabetics.

In a presently preferred embodiment of the invention utilizing ferrocyanide, a number of tests were run showing certain improved operating capabilities.

Referring to Figure 9, a schematic diagram of a preferred circuit 15 for use in the apparatus 10 is shown. Circuit 15 includes a microprocessor and LCD panel 16. The working and reference electrodes on the sample cell 20 make contact at contacts W (working electrode) and R (reference electrode), respectively. Voltage reference 41 is connected to battery 42 through analogue power switch 43. Current from the electrodes W and R is converted by adjustable resistor 44, and voltage to frequency converter 46 electrically connected to the microprocessor. Other circuits within the skills of a practiced engineer can obviously be utilized to obtain the advantages of the present invention.

With regard to Figure 10, cell 400 consists of coplanar working 426 and reference 424 electrodes laminated between an upper 422 and lower 426 nonconducting material. Lamination is on an adhesive layer 425. The upper material 422 includes a die cut opening 428 which, along with the width of the working electrode material defines the working electrode area and provides (with an overlapping reagent layer not depicted) the sampling port of the cell. At one end of cell 400 is an open area 427 similar to end position 27.

The efficiency of using the apparatus according to the present invention to provide a means for in-home self testing by patients such as diabetics (in the preferred embodiment) can be seen in the following table in which the technology according to the present invention is compared to four commercially available units. As will be seen, the present in-

vention is simpler, and in this instance simplicity breeds consistency in results.

GLUCOSE SYSTEM COMPARISONS					
Steps	1	2	3	4	Present Invention
Turn Instrument On	X	X	X	X	X
Calibrate Instrument	X	X			
Finger Puncture	X	X	X	X	X
Apply Blood	X	X	X	X	X
Initiate Timing Sequence	X	X	X		
Blot	X	X	X		
Insert Strip to Read	X	X	X	X	
Read Results	X	X	X	X	X
Total Steps Per Testing	8	8	7	5	4
Detection System	RS*	RS	RS	RS	Polarographic
Range (mg/dl)	10-400	40-400	25-450	40-400	0-1000
CV**Hypoglycemic	15%	15%			5%
Euglycemic	10%	10%			3%
Hyperglycemic	5%	5%			2%
Correlation	0.921	0.862			0.95

(*RS - Reflectance Spectroscopy)

**Coefficient of variation

With specific regard to the determination of cholesterol utilizing the present invention, the generalized chemistry may be depicted as:

Scheme I

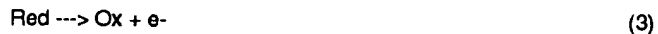
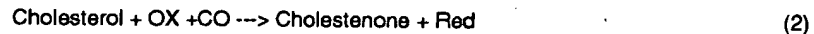

where the enzymes cholesterol esterase (CE) and cholesterol oxidase (CO) catalyze reactions 1 and 2 respectively and CO permits electron transfer with a variety of electroactive couples (Ox and Red). Reaction 2 is novel in that electron acceptors other than dioxygen may be used to oxidize cholesterol in the presence of the enzyme cholesterol oxidase. Reaction 1 is well known to those in the field and is necessary for the determination of total cholesterol (free cholesterol and cholesterol esters). Reaction 3 is an electro-oxidation process for probing and quantitating the cholesterol.

Utilizing alternative oxidants according to the present invention, the specific reactions become:

A:

Reaction 1 above

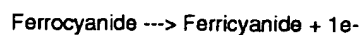
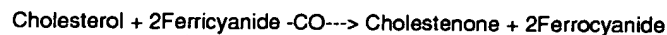

B:

Reaction 1 above

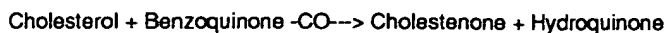

Cholesterol oxidase (CO) from a variety of sources will catalyze electron transfer from cholesterol to a variety of the oxidants including benzoquinone, benzoquinone derivatives such as methylbenzoquinone, ethylbenzoquinone, chlorobenzoquinone, ortho-benzoquinone (oxidized form of catechol), benzoquinonesulfonate, and potassium ferricyanide. It is also anticipated that the enzyme will allow electron transfer with other alternate oxidants. As indicated in Reaction 3, the reduced product can then be monitored amperometrically for the quantitative determination of cholesterol.

Sources of the enzyme catalyzing the oxidation of cholesterol with alternate oxidants include CO from *Nocardia*, *Streptomyces*, *Schizophyllum*, *Pseudomonas*, and *Brevibacterium*; experimental conditions under which it is able to rapidly catalyze the oxidation of cholesterol by benzoquinone or any of the other oxidants depend somewhat upon the source of the enzyme. For example, CO from *Streptomyces* rapidly catalyzes substrate oxidation with benzoquinone in phosphate buffer in the presence of any of a variety of the surfactants including octylgluconopyranoside and CHAPSO; the same reaction under identical conditions with CO from either *Brevibacterium* or *Nocardia* is slower. However, both *Nocardia* and *Brevibacterium* sources are active catalysts for cholesterol oxidation by alternate oxidants under other conditions.

The oxidant also plays a role in which the enzyme is most active. For example, cholesterol oxidase from *Nocardia* rapidly catalyzes substrate oxidation with benzoquinone in 0.2 molar TRIS buffer and 3 g/dL CHAPSO but is slower with ferricyanide under identical conditions; the *Brevibacterium* source of the enzyme is relatively inactive with ferricyanide in TRIS buffer with a variety of surfactants but when benzoquinone is used as the oxidant the reaction is very fast. Alternatively, the *Schizophyllum* source of the enzyme CO rapidly catalyzes the oxidation of cholesterol in phosphate buffer with either ferricyanide or benzoquinone and with a variety of surfactants as activators.

As indicated, cholesterol oxidase will catalyze the oxidation of cholesterol by ferricyanide. Additional examples where CO catalyzes cholesterol oxidation by ferricyanide include a *Nocardia* source in TRIS buffer with a variety of surfactants including sodium deoxycholate, sodium taurodeoxycholate, CHAPS, Thesit, and CHAPSO. Furthermore, CO from *Nocardia* will also catalyze substrate oxidation with ferricyanide in phosphate buffer with sodium dioctylsulfosuccinate, sodium deoxycholate, sodium taurodeoxycholate, and Triton® X-100. The buffer concentration is from 0.1 to 0.4 molar. Surfactant concentration for maximum activity of the oxidase enzyme varies with each detergent. For example, with deoxycholate or taurodeoxycholate, the enzyme in 0.2 M TRIS is most active with detergent in the range from 20 to 90 millimolar. However, enzyme catalytic activity is observed up to and through a 10% concentration. With octyl-gluconopyranoside, the maximum activity of the enzyme with the oxidant ferricyanide occurs at a detergent concentration of approximately 1.2%; however, the enzyme still maintains activity at higher and lower concentrations of the surfactant.

Both esterase and CO require a surfactant for high activity. Specific surfactants include sodium deoxycholate, sodium taurodeoxycholate, sodium glycodeoxycholate, CHAPS (3-(3-chloramidopropyl)dimethylammonio-1-propanesulfonate), CHAPSO (3-(3-chloramidopropyl)dimethylammonio-2-hydroxy-1-propanesulfonate), octyl-gluconopyranoside, octyl-thiogluconopyranoside, nonyl-gluconopyranoside, dodecyl-gluconopyranoside, Triton X-100 ("Triton" is a registered Trade Mark), Dioctyl sulfosuccinate, Thesit (Hydroxypolyethoxydodecane), and lecithin (phosphatidylcholine). Buffers acceptable for this reaction to occur with the enzyme include phosphate, TRIS, MOPS, MES, HEPES, Tricine, Bicine, ACES, CAPS, and TAPS. An alternate generalized reaction scheme for the measurement of cholesterol in serum and other biological fluids is given

Scheme II

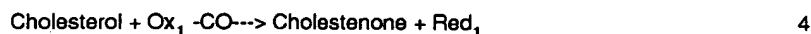

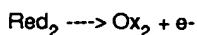

5 where Ox₁ and Red₂ function as an electron mediator couple between the cholesterol and the electroactive couple Ox₂/Red₂. In this case, Ox₁ and Red₁ need not be electroactive because they do not have to participate in the electrooxidation process (Reaction 6). However, from both a thermodynamic and kinetic perspective, this couple with the assistance of the enzyme cholesterol oxidase must be able to accept electrons from cholesterol and relay them to the electroactive couple (Ox₂/Red₂).

10 Specific examples of this chemistry include

Example 1

Reaction 1 above

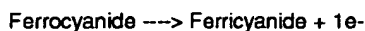
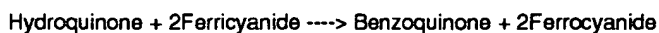
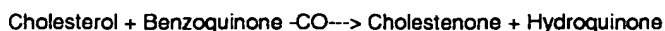

25 Scheme II is beneficial when the rate of reaction of cholesterol with the electroactive oxidant as in Scheme I is so slow that it precludes its use in a practical sensor. As mentioned above, Scheme II is also beneficial when the electron mediator itself (Ox₁/Red₁) is either not electroactive or exhibits poor electrochemistry under conditions of the enzyme chemistry. It is under these conditions that Scheme II is particularly applicable. Other electron mediators (Ox₁/Red₁) between cholesterol and ferricyanide for use in Scheme II may be possible including phenazine ethosulfate, phenazine methosulfate, tetramethylbenzidine, derivatives of benzoquinone, naphthoquinone and naphthoquinone derivatives, anthraquinone and anthraquinone derivatives, catechol, phenylenediamine, tetramethylphenylenediamine, and other derivatives of phenylenediamine.

30 Furthermore, while it is understood that the oxidized form of the electron relay accepts electrons from cholesterol, in the sensor either the oxidized or the reduced form of the mediator may be incorporated provided it reacts rapidly with both cholesterol and ferricyanide. If the reduced form is sufficiently stable and the oxidized form is not, then reductant, may be incorporated into the sensor in relatively small quantity (in comparison with the analyte to be determined) and still provide the electron relay. However, this causes a corresponding background signal that must be accounted for. The reductant, must also be isolated from ferricyanide in the sensor by incorporation into a separate reagent layer.

35 Several formulations of the above chemistries encompassing both Schemes I and II have been prepared as dry films on membranes. These membranes are positioned in the sensor which can then be used for the determination of cholesterol. A preferred formulation of the reagents involving Scheme II consists of the following

40 Cholesterol Esterase @ 400 Units/mL
 Cholesterol Oxidase from Streptomyces @ 200 Units/mL
 45 0.05 molar Potassium Ferricyanide
 0.5 molar Potassium Chloride
 0.2 molar Phosphate, pH 6.9
 3 g/dL CHAPSO
 2 g/dL gelatin
 50 and 0.0001 molar hydroquinone (in the spreading or wicking layer).

55 The concentrations provided are those of the solutions which are coated onto porous supports, filter paper or membranes; these concentrations are reestablished when the membrane imbibes the serum or whole blood specimen. For cholesterol determinations larger pore sizes in the filter support are more necessary than that used for glucose. This is because the cholesterol resides in the serum in large lipoproteins (chylomicrons, LDL, VLDL, and HDL) which must penetrate the various layers of the sensor until they reach the reagents. The surfactants to a major extent break these natural micelles up into smaller micelles providing a greater total surface area on which the enzymes catalyze the

reaction. Due to the instability of benzoquinone a small quantity of hydroquinone, which is more stable by nature of its lower vapor pressure, is incorporated into the sensor to assist electron mediation between cholesterol and ferricyanide. Upon introduction of the serum specimen into the sensor the hydroquinone is oxidized to benzoquinone; the benzoquinone is then free to pick up electrons from the substrate and cycle them to ferricyanide. Under these conditions the rate of the reaction of cholesterol with a small quantity of benzoquinone is more rapid than that with a large excess of ferricyanide.

An alternate and preferred formulation of reagents utilizing Scheme II that may be incorporated into the reagent layer of the sensor is:

- Cholesterol Oxidase from Streptomyces @ 200 Units/mL
- Lipase from Candida @ 500 Units/mL
- 3 g/dL CHAPSO
- 0.2 molar TRIS, pH 7.5
- 0.05 molar Potassium Ferricyanide
- 0.5 molar Potassium Chloride
- 0.05 molar MgCl₂
- 2 g/dL gelatin

and 0.001 molar hydroquinone (in the spreading layer). The magnesium salt in this formulation increases stability of the esterase enzyme in the phosphate-free reagent layer; Lipase assists the break up of the lipoproteins. With these dry reagent layers incorporated into the sensor and using the evaluation methodology as described, the following results were obtained.

Serum Cholesterol, mg%	Average Current, uA
91	19.3
182	27.2
309	38.5

These results demonstrate the quantitative response of the sensor to serum cholesterol levels. Alternate and preferred embodiment of the sensor utilizing Scheme I is provided by reagent compositions:

- Cholesterol Esterase @ 400 Units/mL
- Cholesterol Oxidase from Nocardia @ 200 Units/mL
- 1 g/dL Triton X®-100
- 0.1 molar TRIS buffer, pH 8.6
- 0.2 molar Potassium Ferricyanide
- 0.5 molar Potassium Chloride
- 0.02 molar MgCl₂
- 2 g/dL gelatin

OR

- Cholesterol Esterase @ 200 Units/mL
- Cholesterol Oxidase from Streptomyces @ 200 Units/mL
- 0.06 molar Sodium deoxycholate
- 0.1 molar TRIS buffer, pH 8.6
- 0.2 molar Potassium Ferricyanide
- 0.5 molar Potassium Chloride
- 2 g/dL gelatin

Thus, while we have illustrated and described the preferred embodiment of my invention, it is to be understood that this invention is capable of variation and modification, and we therefore do not wish or intend to be limited to the precise terms set forth, but desire and intend to avail ourselves of such changes and alterations which may be made for adapting the invention of the present invention to various usages and conditions. The terms and expressions which have been employed in the foregoing specifications are used therein as terms of description and not of limitation, and thus there is no intention, in the use of such terms and expressions, of excluding equivalents of the features shown and described or portions thereof, it being recognized that the scope of the invention is defined and limited only by the

claims which follow.

Having thus described our invention and the manner and process of making and using it in such full, clear, concise, and exact terms so as to enable any person skilled in the art to which it pertains, or to with which it is most nearly connected, to make and use the same.

5

Claims

1. A method for measuring the amount of a selected compound in body fluids comprising,

10

- a) providing a measuring cell (20, 120, 400) having a first (26, 126, 226, 426) and second electrode (24, 124, 224, 424) and said cell (20, 120, 400) containing an oxidant and a buffer,
- b) placing a sample of fluid to be tested in said cell (20, 120, 400),
- c) reconstituting said oxidant and buffer with said sample fluid to generate a predetermined catalyzed reaction,
- d) allowing said reaction to proceed substantially to completion,
- e) applying a potential across said electrodes (26, 126, 226, 426, 24, 124, 224, 424) and sample, and
- f) measuring the resultant Cottrell current to determine the concentration of said selected compound present in said sample,

15

20

wherein the placing of the sample of fluid to be tested in said cell in step (b) causes a charging current to flow which is detected and begins a reaction incubation step to allow the predetermined catalysed reaction substantially to reach completion and then causes a potential to be applied across said electrodes and causes the Cottrell current to be measured at specific time points during the Cottrell current decay.

25

2. The method as set forth in Claim 1, wherein the selected compound is selected from glucose, cholesterol, TSH, T4, hormones, antiarrhythmics, antiepileptics, and nontherapeutic drugs.

30

3. The method as set forth in Claim 1 or Claim 2, wherein the oxidant is a material selected from benzoquinone, ferricyanide, ferricinium, cobalt (III) orthophenanthroline and cobalt (III) dipyriddy.

35

4. The method as set forth in any preceding claim including providing as said first electrode (26, 126, 226, 426) a working electrode (26, 126, 226, 426) and as said second electrode (24, 124, 224, 424) an electrode which acts as a reference electrode or a pseudo reference electrode (24, 124, 224, 424).

40

6. The method of any preceding claim, including selecting said buffer from phosphate, TRIS, MOPS, MES, HEPES, Tricine, Bicine, ACES, CAPS and TAPS.

45

7. The method as set forth in Claim 1, wherein the selected compound is glucose and the body fluid is blood, the measuring cell (20, 120, 400) of step (a) further includes an enzyme for catalyzing said catalyzed reaction, the reconstituting step (c) reconstitutes said oxidant, said buffer and said enzyme with said blood sample to produce the predetermined reaction, and the potential across said electrodes (26, 126, 226, 426, 24, 124, 224, 424) of step (e) is applied following substantial completion of the reaction.

50

8. The method of Claim 7 wherein said oxidant is suitable, in the presence of said enzyme, to oxidise the selected compound during said predetermined reaction and is selected from benzoquinone, ferricyanide, ferricinium, Cobalt (III) orthophenanthroline and Cobalt (III) dipyriddy.

55

9. The method of Claim 7 or Claim 8 including providing as said first electrode (26, 126, 226, 426) a working electrode (26, 126, 226, 426) and as said second electrode (24, 124, 224, 424) an electrode which acts as a reference electrode or a pseudo reference electrode (24, 124, 224, 424).

10. The method of any one of Claims 7-9, including adding as said enzyme, glucose oxidase.

11. A sample cell (20, 120, 400) for determining the concentration of a selected compound in a sample body fluid, comprising,

a) a metallized first electrode (26, 126, 226, 426) which acts as a working electrode (26, 126, 226, 426),
 b) a metallized second electrode (24, 124, 224, 424) which acts as a reference electrode or a pseudo reference electrode (24, 124, 224, 424), said second electrode (24, 124, 224, 424) being operatively associated with said first electrode (26, 126, 226, 426);

5 c) at least one non-conducting layer member (22, 122, 222, 422) having an opening (21, 121, 221, 428) there-through, said non-conducting layer member (22, 122, 222, 422) being disposed in contact with at least one of said electrodes (26, 126, 226, 426, 24, 124, 224, 424) and said non-conducting layer member (22, 122, 222, 422) being sealed against at least one of said first (26, 126, 226, 426) and second electrodes (24, 124, 224, 424) to form a known electrode area within said opening (21, 121, 221, 428) such that said opening (21, 121, 221, 428) forms a well to receive said sample body fluid and to allow placement of said fluid in said known electrode area in contact with said first electrode (26, 126, 226, 426) and second electrode (24, 124, 224, 424), said cell (20, 120, 400) also including a reagent layer positioned within said well created by said opening (21, 121, 221, 428) wherein said reagent layer contains an oxidant, a buffer, and a binding agent, whereby the contents of said well (21, 121, 221, 428) are capable of being subjected to a predetermined catalyzed reaction;

15 d) means for applying a potential across said electrodes after said predetermined catalyzed reaction has proceeded substantially to completion; and

20 e) means for measuring the resulting Cottrell current following application of said potential; wherein the cell also comprises means for causing a charging current to flow upon placement of said fluid in said known electrode area to detect the presence of said fluid, which begins a reaction incubation step to allow the predetermined catalyzed reaction substantially to reach completion and which then causes a potential to be applied across said electrodes by said means (d) and causes the Cottrell current to be measured at specific time points during the Cottrell current decay by said means (e).

25 12. The cell (20, 120, 400) of Claim 11 wherein said reagent layer is a layer of said oxidant, buffer and binding agent coated onto a porous matrix and said matrix is positioned within said cell (20, 120, 400).

30 13. The cell (20, 120, 400) of Claim 11 wherein said reagent layer is a mixture of said oxidant, buffer and binding agent deposited directly into said cell (20, 120, 400).

14. The cell (20, 120, 400) of any one of Claims 11-13, wherein said oxidant is suitable, in the presence of said enzyme, to oxidise the selected compound during said predetermined reaction and is selected from the group consisting of benzoquinone, ferricyanide, ferricinium, Cobalt (III) orthophenanthroline and Cobalt (III) dipirydyl.

35 15. The cell (20, 120, 400) of any one of Claims 11-14, wherein said buffer is selected from phosphate, TRIS, MOPS, MES, HEPES, Tricine, Bicine, ACES, CAPS and TAPS.

16. The cell (20, 120, 400) of any one of Claims 11-15, wherein said reagent layer also includes an enzyme.

40 17. The cell (20, 120, 400) of any one of Claims 11-16, wherein said first electrode (26, 126, 226, 426) is composed of a non-conducting substrate coated with a metal.

18. The cell (20, 120, 400) of any one of Claims 11-17, wherein said second electrode (24, 124, 224, 424) is composed of a non-conducting substrate coated with a metal.

45 19. The cell (20, 120, 400) of any one of Claims 11-18, wherein said second electrode (24, 124, 224, 424) is a pseudo reference electrode and the first (26, 126, 226, 426) and second (24, 124, 224, 424) electrodes are of the same noble metal.

50 20. The cell (20) of any one of Claims 11-19, wherein a first non-conducting layer member (22, 222) having an opening (21, 221) therethrough is positioned on said first electrode (26, 226), and said first electrode (26, 226) is positioned on said second electrode (24, 224), and said second electrode (24, 224) is positioned on a second non-conducting layer member (23, 223).

55 21. The cell (120) of any one of Claims 11-19 wherein a first non-conducting layer member (122, 222) includes a plurality of notches (131, 132, 231, 232) therein exposing and defining an electrical contact area on said first electrode (126, 226), and said first electrode (126, 226) has a notch (133, 234) therein to expose and define an electrical contact area on said second electrode (124, 224).

22. The cell of Claim 20, wherein said first electrode (226) is folded with corresponding openings in each fold creating a well in which to hold said sample fluid, said first electrode (226) being positioned with respect to said first non-conducting layer (222) member such that the opening in said first non-conducting layer (222) is juxtaposed with said openings in said first electrode (226).

23. The cell (400) of any one of Claims 11-19, wherein said first (426) and second electrodes (424) are coplanarly positioned on a single substrate.

24. The cell (120) of any one of Claims 11-19 and 21, wherein said second electrode (124) has a circular opening therein and said opening (121) of said layer member (122) is concentric with said opening in said second electrode (124), and said opening in said second electrode (124) is of smaller diameter than said opening (121) of said layer member (122) whereby a circular functional electrode area is defined on said second electrode (124), and said first electrode (126) is positioned beneath said second electrode (124) such that said opening in said second electrode (124) exposes and defines a functional electrode area on said first electrode (126).

25. An apparatus for measuring compounds in a sample body fluid, comprising:

- a. a housing (11, 12) having an access opening (19) therethrough,
- b. a sample cell (20, 120, 400) receivable into said access opening (19) of said housing (11, 12), said sample cell (20, 120, 400) being as defined in any one of Claims 11-24,
- c. means for creating an electrical circuit between said first electrode (26, 126, 226, 426) and said second electrode (24, 124, 224, 424) through said sample body fluid, and
- d. means for visually displaying a measurement of said sample body fluid made by said apparatus, wherein the apparatus also comprises means for initiating an electrical potential upon insertion of said sample cell to detect the presence of said sample body fluid, said initiating means also having means for removing said potential once the sample body fluid has been detected.

26. The apparatus of Claim 25, wherein said means of said cell for measuring Cottrell current through said sample body fluid includes a microprocessor.

Patentansprüche

1. Verfahren zum Messen der Menge einer ausgewählten Verbindung in Körperflüssigkeiten mit folgenden Verfahrensschritten:

- a) eine Messzelle (20, 120, 400) mit einer ersten (26, 126, 226, 426) und einer zweiten Elektrode (24, 124, 224, 424) wird bereit gestellt, in dieser Zelle (20, 120, 400) befinden sich ein Oxidationsmittel und ein Puffer,
- b) eine Probe der zu testenden Flüssigkeit wird in diese Zelle (20, 120, 400) eingebracht,
- c) das Oxidationsmittel und der Puffer werden mit der Flüssigkeitsprobe rekonstituiert um eine vorbestimmte katalytische Reaktion zu generieren,
- d) man läßt die Reaktion im wesentlichen zum Abschluß kommen,
- e) es wird ein Potential an den Elektroden (26, 126, 226, 426, 24, 124, 224, 424) und der Probe angelegt und
- f) es wird der resultierende Cottrellstrom gemessen, um die Konzentration der ausgewählten Verbindung in der Probe zu erfassen,

wobei das Einbringen der zu testenden Flüssigkeitsprobe in die Zelle in Schritt (b) das Fließen eines Ladestroms zur Folge hat, der erfaßt wird und einen Inkubationsschritt der Reaktion beginnt, so dass die vorgegebene katalytische Reaktion im wesentlichen ihren Abschluß erreicht und dann ein an den Elektroden angelegtes Potential zur Folge hat und schließlich zur Folge hat, dass der Cottrellstrom zu vorgegebenen Zeitpunkten während des Abfalls des Cottrellstroms gemessen wird.

2. Verfahren nach Anspruch 1, wobei die ausgewählte Verbindung ausgewählt ist aus Glucose, Cholesterol, TSH, T4, Hormone, Antiarrhythmika, Antiepileptika und nicht therapeutischen Heilmitteln.

3. Verfahren nach Anspruch 1 oder 2, wobei das Oxidationsmittel ein Material ist, das ausgewählt ist aus Benzochinon, Ferricyanid, Ferricinium, Kobalt(III)-orthophenanthrolin und Kobalt(III)-dipyridyl.

4. Verfahren nach einem der vorausgegangenen Ansprüche einschließlich Bereitstellen einer Arbeitselektrode (26, 126, 226, 426) als die genannte erste Elektrode (26, 126, 226, 426) und einer Elektrode, die als Referenzelektrode oder als Pseudoreferenzelektrode (24, 124, 224, 424) wirkt, als zweite Elektrode (24, 124, 224, 424).
5. Verfahren nach einem der vorausgegangenen Ansprüche, bei dem zusätzlich in der Zelle (20, 120, 400) ein Enzym als Katalysator für die genannte katalytische Reaktion bereitgestellt wird.
6. Verfahren nach einem der vorangegangenen Ansprüche, bei dem zusätzlich die Auswahl des Puffers aus Phosphat, TRIS, MOPS, MES, HEPES, Tricin, Bicin, ACES, CAPS and TAPS erfolgt.
7. Verfahren nach Anspruch 1, wobei die ausgewählte Verbindung Glucose und die Körperflüssigkeit Blut ist, die Meßzelle (20, 120, 400) des Verfahrensschritts (a) weiterhin ein Enzym für das Katalysieren der Katalysatorreaktion enthält, der Schritt des Rekonstituierens (c) das Oxidationsmittel, den Puffer und das Enzym mit der Blutprobe rekonstituiert, um die vorgegebene Reaktion hervorzurufen, und das Potential über die Elektroden (26, 126, 226, 426, 24, 124, 224, 424) gemäß Verfahrensschritt (e) angelegt wird nach im wesentlichen Abschluß der Reaktion.
8. Verfahren nach Anspruch 7, wobei das Oxidationsmittel geeignet ist in Anwesenheit des genannten Enzyms die ausgewählte Verbindung während der vorgegebenen Reaktion zu oxidieren und ausgewählt ist aus Benzochinon, Ferricyanid, Ferricinium, Kobalt(III)-orthophenanthrolin und Kobalt(III)-dipyridyl.
9. Verfahren nach Anspruch 7 oder 8, einschließlich Bereitstellen einer Arbeitselektrode (26, 126, 226, 426) als die genannte erste Elektrode (26, 126, 226, 426) und als zweite Elektrode (24, 124, 224, 424) einer Elektrode, die als Referenzelektrode oder als Pseudoreferenzelektrode (24, 124, 224, 424) wirkt.
10. Verfahren nach einem der Ansprüche 7 bis 9, bei dem zusätzlich Glucoseoxidase als Enzym hinzugefügt wird.
11. Eine Probenzelle (20, 120, 400) für die Bestimmung der Konzentration einer ausgewählten Verbindung in einer Probe an Körperflüssigkeit, mit
 - a) einer metallisierten ersten Elektrode (26, 126, 226, 426), die als Arbeitselektrode (26, 126, 226, 426) eingesetzt ist;
 - b) einer metallisierten zweiten Elektroden (24, 124, 224, 424), die als Referenzelektrode oder Pseudoreferenzelektrode (24, 124, 224, 424) eingesetzt ist, diese zweite Elektrode (24, 124, 224, 424) ist der ersten Elektrode (26, 126, 226, 426) operativ zugeordnet;
 - c) zumindest einem nichtleitenden Schichtteil (22, 122, 222, 422), das eine durchgehende Öffnung (21, 121, 221, 428) aufweist, dieses nichtleitende Schichtmittel (22, 122, 222, 422) ist in Kontakt mit zumindest einer der Elektroden (26, 126, 226, 426, 24, 124, 224, 424) angeordnet und es ist mit mindestens einer der ersten (26, 126, 226, 426) und zweiten Elektroden (24, 124, 224, 424) dicht verbunden, so dass eine vorgegebene Elektrodenfläche innerhalb der genannten Öffnung (21, 121, 221, 428) gebildet wird, so dass diese Öffnung (21, 121, 221, 428) eine Vertiefung bildet, die die genannte Probe an Körperflüssigkeit aufnimmt und es erlaubt, dass die Flüssigkeit auf der bekannten Elektrodenfläche in Kontakt mit der ersten Elektrode (26, 126, 226, 426) und der zweiten Elektrode (24, 124, 224, 424) gebracht wird, dabei hat die Zelle (20, 120, 400) weiterhin eine Reagenzschicht, die innerhalb der von der Öffnung (21, 121, 221, 428) hervorgerufenen Vertiefung angeordnet ist, wobei diese Reagenzschicht ein Oxidationsmittel, einen Puffer und ein Bindemittel enthält und wobei die Bestandteile der genannten Vertiefung (21, 121, 221, 428) geeignet sind, der vorgegebenen katalytischen Reaktion unterworfen zu werden;
 - d) Mitteln zum Anlegen eines Potentials an die Elektroden, wenn die vorgegebene katalytische Reaktion im wesentlichen abgeschlossen ist und
 - e) Mitteln zum Erfassen des resultierenden Cottrellstroms, der dem Anlegen des genannten Potentials folgt, wobei die Zelle auch Mittel aufweist, um das Fließen eines Ladestroms hervorzurufen, wenn die genannte Flüssigkeit an der bekannten Elektrodenfläche angeordnet ist, um die Anwesenheit dieser Flüssigkeit zu erfassen und wobei ein Reaktionsinkubationsschritt beginnt, um die vorgegebene katalytische Reaktion im wesentlichen zum Abschluß zu bringen, was dann zur Folge hat, dass ein Potential an den Elektroden mittels der Mittel (d) angelegt wird und weiterhin zur Folge hat, dass der Cottrellstrom zu vorgegebenen Zeitpunkten während des Abfalls des Cottrellstroms durch die genannten Mittel (e) erfaßt wird.
12. Zelle (20, 120, 400) nach Anspruch 11, wobei die genannte Reagenzschicht eine Schicht aus dem Oxidationsmittel, Puffer und Bindemittel ist, die auf eine poröse Matrix aufgezogen ist und wobei diese Matrix innerhalb der Zelle

(20, 120, 400) positioniert ist.

- 5
13. Zelle (20, 120, 400) nach Anspruch 11, wobei die Reagenzschicht eine Mischung ist aus dem genannten Oxidationsmittel, Puffer und Bindemittel, die direkt innen auf die Zelle (20, 120, 400) aufgebracht ist.
- 10
14. Zelle (20, 120, 400) nach einem der Ansprüche 11 bis 13, wobei das Oxidationsmittel geeignet ist in Anwesenheit des genannten Enzyms die ausgewählte Verbindung während der vorgegebenen Reaktion zu oxidieren und ausgewählt ist aus der Gruppe bestehend aus Benzochinon, Ferricyanid, Ferricinium, Kobalt(III)-orthophenanthrolin und Kobalt(III)-dipyridyl.
- 15
15. Zelle (20, 120, 400) nach einem der Ansprüche 11 bis 14, wobei der genannte Puffer ausgewählt ist aus Phosphat, TRIS, MOPS, MES, HEPES, Tricin, Bicin, ACES, CAPS und TAPS.
16. Zelle (20, 120, 400) nach einem der Ansprüche 11 bis 15, wobei die Reagenzschicht auch ein Enzym aufweist.
17. Zelle (20, 120, 400) nach einem der Ansprüche 11 bis 16, wobei die erste Elektrode (26, 126, 226, 426) zusammengesetzt ist aus einem nicht leitenden Substrat, das mit Metall überzogen ist.
18. Zelle (20, 120, 400) nach einem der Ansprüche 11 bis 17, wobei die zweite Elektrode (24, 124, 224, 424) zusammengesetzt ist aus einem nicht leitenden Substrat, das mit Metall überzogen ist.
19. Zelle (20, 120, 400) nach einem der Ansprüche 11 bis 18, wobei die zweite Elektrode (24, 124, 224, 424) eine Pseudoreferenzelektrode ist und die erste Elektrode (26, 126, 226, 426) und die zweite Elektrode (24, 124, 224, 424) aus demselben Edelmetall sind.
- 20
20. Zelle (20) nach einem der Ansprüche 11 bis 19, wobei ein erstes, nicht leitendes Schichtmittel (22, 222), das eine durchgehende Öffnung (21, 221) aufweist, auf der ersten Elektrode (26, 226) angeordnet ist und die erste Elektrode (26, 226) auf der zweiten Elektrode (24, 224) positioniert ist und wobei diese zweite Elektrode (24, 224) positioniert ist auf einem zweiten nichtleitenden Schichtmittel (23, 223).
- 25
21. Zelle (120) nach einem der Ansprüche 11 bis 19, wobei ein erstes nichtleitendes Schichtmittel (122, 222) eine Vielzahl von Ausnehmungen (131, 132, 231, 232) in sich aufweist, die einen elektrischen Kontaktbereich auf der ersten Elektrode (126, 226) freilassen und definieren, und wobei die erste Elektrode (126, 226) eine Ausnehmung (133, 234) in sich hat, um eine elektrische Kontaktfläche an dieser zweiten Elektrode (124, 224) freizugeben und zu definieren.
- 30
22. Zelle nach Anspruch 20, wobei die erste Elektrode (226) gefaltet ist mit entsprechenden Öffnungen in jeder Falte unter Bildung einer Vertiefung, in welcher die Probenflüssigkeit aufgenommen wird, wobei diese erste Elektrode (226) bezüglich des genannten ersten nichtleitenden Schichtmittels (222) so positioniert ist, dass die Öffnung in diesem ersten nichtleitenden Schichtmittel (222) neben den Öffnungen in dieser ersten Elektrode (226) liegt.
- 35
23. Zelle (400) nach einem der Ansprüche 11 bis 19, wobei die erste Elektrode (426) und die zweite Elektrode (424) coplanar auf einem einzigen Substrat positioniert sind.
- 40
24. Zelle (120) nach einem der Ansprüche 11 bis 19 und 21, wobei die genannte zweite Elektrode (124) eine kreisförmige Öffnung in sich aufweist und die genannte Öffnung (121) des Schichtmittels (122) konzentrisch ist mit dieser Öffnung in der zweiten Elektrode (124), und wobei diese Öffnung in der zweiten Elektrode (12) einen geringeren Durchmesser hat als die Öffnung (121) in dem genannten Schichtmittel (122), wobei eine kreisförmige Elektrodenfunktionsfläche auf dieser zweiten Elektrode (124) definiert wird, und wobei die erste Elektrode (126) unterhalb der zweiten Elektrode (124) so positioniert ist, dass die Öffnung in der zweiten Elektrode (124) eine Elektrodenfunktionsfläche auf der ersten Elektrode (126) freigibt und definiert.
- 45
25. Vorrichtung zur Messung von Verbindungen in einer Probe an Körperflüssigkeit, mit
- 50
- a) einem Gehäuse (11, 12), das eine Zugangsöffnung (19) in sich aufweist,
- b) einer Probenzelle (20, 120, 400), die durch die Zugangsöffnung (19) des genannten Gehäuses (11, 12) in dieses eingebracht werden kann, wobei diese Probenzelle (20, 120, 400) definiert ist durch einen der Ansprüche 11 bis 24,
- 55

c) Mitteln, um einen elektrischen Kreis zwischen der genannten ersten Elektrode (26, 126, 226, 426) und der zweiten Elektrode (24, 124, 224, 424) durch die Probe an Körperflüssigkeit hervorzurufen und
d) Mitteln, um eine Messung der Probe an Körperflüssigkeit, die in der genannten Aparatur durchgeführt wird, visuell anzuzeigen, wobei die Vorrichtung auch Mittel aufweist, um ein elektrisches Potential nach Einbringen der Probenzelle hervorzurufen, um das Vorhandensein der Probe an Körperflüssigkeit erfassen zu können, und wobei die genannten Mittel zum Aufbringen einer Spannung auch Mittel aufweisen, um das Potential zu entfernen, wenn die Probe an Körperflüssigkeit erfaßt wurde.

26. Vorrichtung nach Anspruch 25, wobei die Mittel der Zelle für die Erfassung des Cottrellstroms durch die Probe an Körperflüssigkeit einen Mikroprozessor aufweisen.

Revendications

1. Procédé de mesure de la proportion d'un composant sélectionné dans les fluides corporels comprenant :

- a) fourniture d'une cellule de mesure (20, 120, 400) ayant une première (26, 126, 226, 426) et une seconde électrode (24, 124, 224, 424) contenant un oxydant et un tampon,
- b) disposition de l'échantillon de fluide dans la cellule (20, 120, 400),
- c) reconstitution desdits oxydant et tampon dans l'échantillon de fluide pour générer une réaction catalytique,
- d) obtention de la réaction sensiblement complète,
- e) application d'un potentiel entre les électrodes (26, 126, 226, 426, 24, 124, 224, 424) et l'échantillon, et
- f) mesure de courant Cottrell résultant pour déterminer la concentration dudit composant sélectionné dans ledit échantillon,

dans lequel la mise en place de l'échantillon de fluide à tester dans ladite cellule au cours de l'étape (b) provoque le flux d'un courant de charge qui est détecté et initie une étape de réaction d'incubation pour permettre à la réaction catalytique d'atteindre son exécution sensiblement complète et ensuite l'application d'un potentiel entre lesdites électrodes permet la mesure du courant de Cottrell à des intervalles de temps spécifiques durant la décroissance de courant de Cottrell.

2. Procédé selon la revendication 1 dans lequel le composant sélectionné est choisi dans les corps suivants : glucose, cholestérol, TSH, T4, hormones, antiarythmiques, antiépileptiques et drogues non thérapeutiques.

3. Procédé selon la revendication 1 ou 2 dans lequel l'oxydant est choisi dans les corps suivants : benzoquinone, ferricyanure, ferricinium, orthophenanthroline (III) de cobalt et dipyridyle (III) de cobalt.

4. Procédé selon l'une des revendications précédentes, incluant en tant que première électrode une électrode de travail (26, 126, 226, 426) et en tant que seconde électrode une électrode (24, 124, 224, 424) agissant comme une électrode de référence ou de pseudo référence.

5. Procédé selon l'une des revendications précédentes incluant aussi l'introduction dans ladite cellule (20, 120, 400) d'une enzyme comme catalyseur de ladite réaction catalysée.

6. Procédé selon l'une des revendications précédentes incluant le choix du tampon parmi le phosphate, TRIS, MOPS, MES, HEPES, Tricine, Bicine, ACES, CAPS et TAPS.

7. Procédé selon la revendication 1, caractérisé en ce que le composant sélectionné est le glucose et le fluide corporel le sang, la cellule de mesure (20, 120, 400) de l'étape (a) incluant de plus une enzyme pour catalyser ladite réaction, l'étape (c) de reconstitution reconstituant ledit oxydant, le tampon, et ladite enzyme avec l'échantillon de sang pour produire la réaction prédéterminée et le potentiel entre les électrodes (26, 126, 226, 426, 24, 124, 224, 424) de l'étape (e) est appliqué après l'achèvement substantiel de la réaction.

8. Procédé selon la revendication 7, dans lequel ledit oxydant est adapté, en présence de ladite enzyme pour oxyder le composant déterminé durant la réaction et choisi parmi la benzoquinone, le ferricyanure, le ferrocinium, l'orthophenanthroline (III) de cobalt et le dipyridyle (III) de cobalt.

9. Procédé selon la revendication 7 ou 8 incluant la disposition de ladite première électrode en tant qu'électrode de

travail (26, 126, 226, 426) et de ladite seconde électrode (24, 124, 224, 424) agissant en tant qu'électrode de référence de pseudo référence.

10. Procédé selon l'une des revendications 7 à 9 incluant l'addition d'oxydase de glucose en tant qu'enzyme.

11. Cellule d'échantillonnage (20, 120, 400) pour déterminer la concentration d'un composant sélectionné dans un fluide corporel comprenant :

- a) une première électrode métallisée (26, 126, 226, 426) agissant comme électrode de travail,
- b) une seconde électrode métallisée (24, 124, 224, 424) qui agit comme électrode de référence ou de pseudo référence, ladite seconde électrode étant opérationnellement associée à la première électrode (26, 126, 226, 426),
- c) au moins une couche non conductrice (22, 122, 222, 422) percée d'une ouverture (21, 121, 221, 428), ladite couche non conductrice étant disposée en contact avec au moins l'une desdites électrodes (26, 126, 226, 426, 24, 124, 224, 424) et étant scellée sur l'une ou l'autre des électrodes pour former une zone connue d'électrode avec l'ouverture (21, 121, 221, 428) de sorte que ladite ouverture (21, 121, 221, 428) forme un puits pour recevoir ledit échantillon de fluide corporel et pour permettre le placement dudit fluide dans ladite zone connue en contact avec ladite première électrode (26, 126, 226, 426) et seconde électrode (24, 124, 224, 424), ladite cellule incluant également une couche réactive positionnée dans le puits créé par ladite ouverture (21, 121, 221, 428) dans lequel ladite couche réactive qui contient un oxydant, un tampon et un agent de liaison, le contenu dudit puits (21, 121, 221, 428) étant apte à subir une réaction catalysée prédéterminée,
- d) des moyens pour appliquer un potentiel entre les électrodes après que ladite réaction ait été substantiellement achevée, et
- e) des moyens pour mesurer le courant de Cottrell résultant de l'application dudit potentiel, la cellule comprenant également des moyens pour charger un courant circulant après le placement dudit fluide dans la zone d'électrode connue qui initie l'étape de réaction d'incubation pour permettre l'achèvement substantiel de la réaction catalysée et provoque ensuite l'application d'un potentiel par lesdits moyens (d) et la lecture de la mesure du courant de Cottrell à intervalles de temps déterminés durant la décroissance de courant de Cottrell par lesdits moyens (e).

12. Cellule (20, 120, 400) selon la revendication 11 dans laquelle ladite couche réactive est une couche de l'oxydant, tampon et agent de liaison, revêtant une matrice poreuse, ladite matrice étant positionnée dans la cellule (20, 120, 400).

13. Cellule (20, 120, 400) selon la revendication 11 dans laquelle la couche réactive est un mélange d'oxydant, de tampon et d'agent de liaison déposé directement sur une matrice poreuse dans ladite cellule (20, 120, 400).

14. Cellule (20, 120, 400) selon l'une des revendications 11 à 13 dans laquelle ledit oxydant est convenable pour oxyder le composant sélectionné, en présence de ladite enzyme durant la réaction prédéterminée et est choisie dans le groupe composé de : benzoquinone, ferricyanure, ferricinium, orthophenanthroline (III) de cobalt et dipyridile (III) de cobalt.

15. Cellule (20, 120, 400) selon l'une des revendications 11 à 14 dans laquelle ledit tampon est choisi dans les phosphates, TRIS, MOPS, MES, HEPES, Tricine, Bicine, ACES, CAPS et TAPS.

16. Cellule (20, 120, 400) selon l'une des revendications 11 à 15 dans laquelle la couche réactive inclut aussi une enzyme.

17. Cellule (20, 120, 400) selon l'une des revendications 11 à 16 dans laquelle la première électrode (26, 126, 226, 426) est composée d'un substrat non conducteur revêtu d'un métal.

18. Cellule (20, 120, 400) selon l'une des revendications 11 à 17 dans laquelle la seconde électrode (24, 124, 224, 424) est composée d'un substrat non conducteur revêtu d'un métal.

19. Cellule (20, 120, 400) selon l'une des revendications 11 à 18 dans laquelle la seconde électrode (24, 124, 224, 424) est une électrode de pseudo référence, la première (26, 126, 226, 426) et la seconde (24, 124, 224, 424) électrodes étant fabriquées dans un même métal noble.

20. Cellule (20) selon l'une des revendications 11 à 19 dans laquelle un premier organe à couche non conductrice (22, 222) percé d'une ouverture (21, 221) est positionné sur ladite première électrode (26, 226), ladite première électrode étant positionnée sur la seconde électrode (24, 224), la seconde électrode étant positionnée sur une seconde couche non conductrice (23, 223).

5

21. Cellule (20) selon l'une des revendications 11 à 19 dans laquelle une première couche non conductrice (122, 222) inclut un ensemble d'entailles (131, 132, 231, 232) définissant une zone de contact électrique sur la première électrode (126, 226), ladite première électrode ayant une entaille (133, 234) pour définir une zone de contact électrique sur ladite seconde électrode (124, 224).

10

22. Cellule selon la revendication 20, dans laquelle ladite première électrode (226) est pliée, avec des ouvertures correspondantes dans chaque pli, pour créer un puits pour maintenir l'échantillon fluide, la première électrode (226) étant positionnée à la première couche non conductrice (222) de sorte que l'ouverture dans la première couche non conductrice soit juxtaposée auxdites ouvertures dans la première électrode (226).

15

23. Cellule (400) selon l'une des revendications 11 à 19 dans laquelle les première (426) et seconde (424) électrodes sont coplanaires sur un substrat unique.

24. Cellule (120) selon l'une des revendications 11 à 19 et 21 dans laquelle la seconde électrode (124) est percée d'une ouverture circulaire, l'ouverture (121) de ladite couche (122) étant concentrique à l'ouverture de la seconde électrode (124), l'ouverture dans ladite seconde électrode (124) étant de diamètre plus petit que l'ouverture (121) de la couche (122) de sorte qu'une zone circulaire d'électrode soit définie sur ladite seconde électrode, la première électrode (126) étant positionnée au-dessous de la seconde électrode (124) de sorte que l'ouverture dans la seconde électrode (124) définisse une zone fonctionnelle d'électrode sur ladite première électrode (126).

25

25. Appareil pour mesurer les composants dans un échantillon de fluide corporel comprenant :

a) un logement (11, 12) percé d'ouverture d'accès (19),

b) une cellule d'échantillon (20, 120, 400) logeable à travers une ouverture d'accès (19) dudit logement (11, 12) ladite cellule étant définie dans une des revendications 11 à 24,

c) des moyens de création d'un circuit électrique entre ladite première électrode (26, 126, 226, 426) et ladite seconde électrode (24, 124, 224, 424) à travers l'échantillon de fluide corporel, et

d) des moyens d'affichage d'une mesure du fluide corporel par l'appareil, celui-ci comprenant des moyens d'application d'une tension après insertion de la cellule pour détecter la présence de celle-ci, ces moyens d'application ayant des moyens d'annulation du potentiel une fois que le fluide corporel a été détecté.

35

26. Appareil selon la revendication 25 dans lequel lesdits moyens de mesure du courant de Cottrell à travers ledit échantillon incluent un microprocesseur.

40

45

50

55

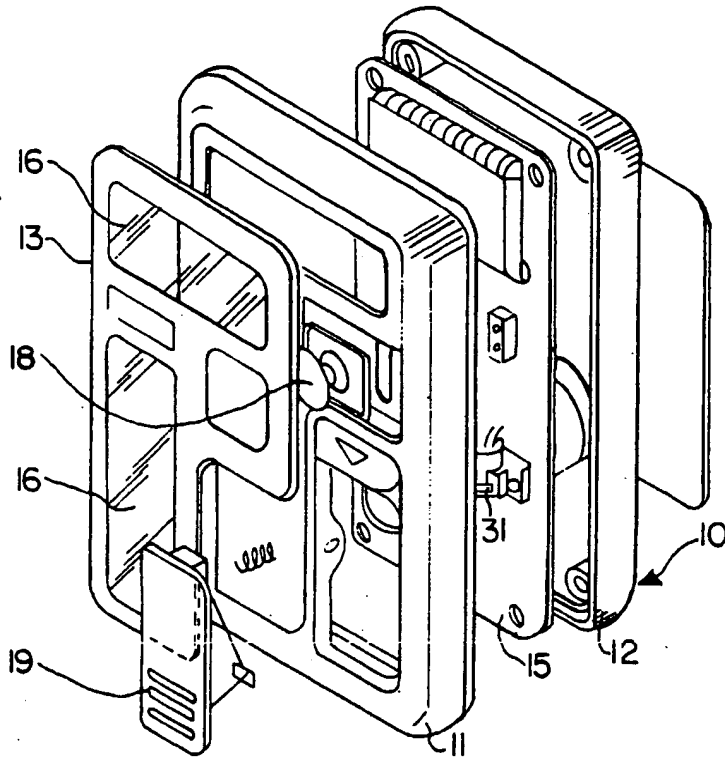

FIG. 1

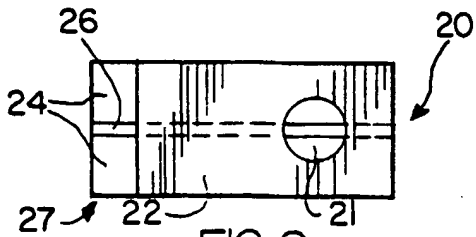

FIG. 2

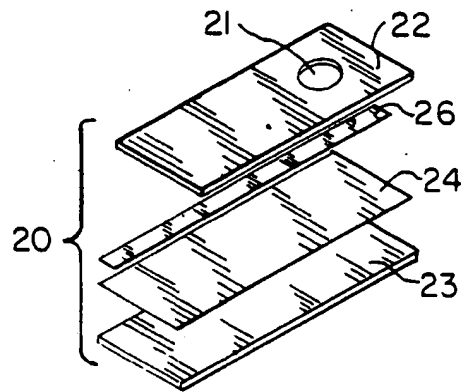

FIG. 3

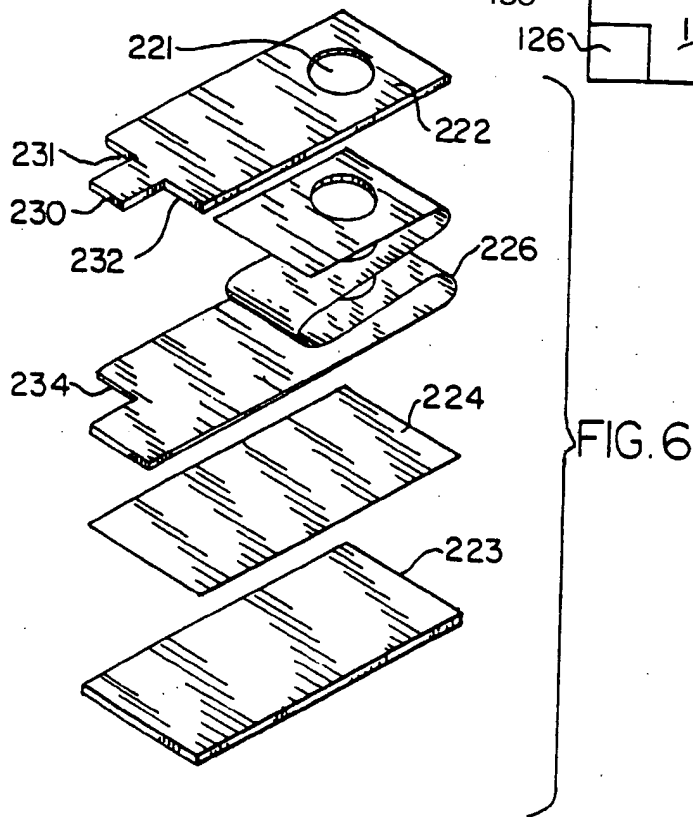
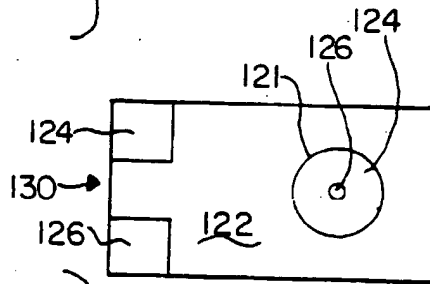
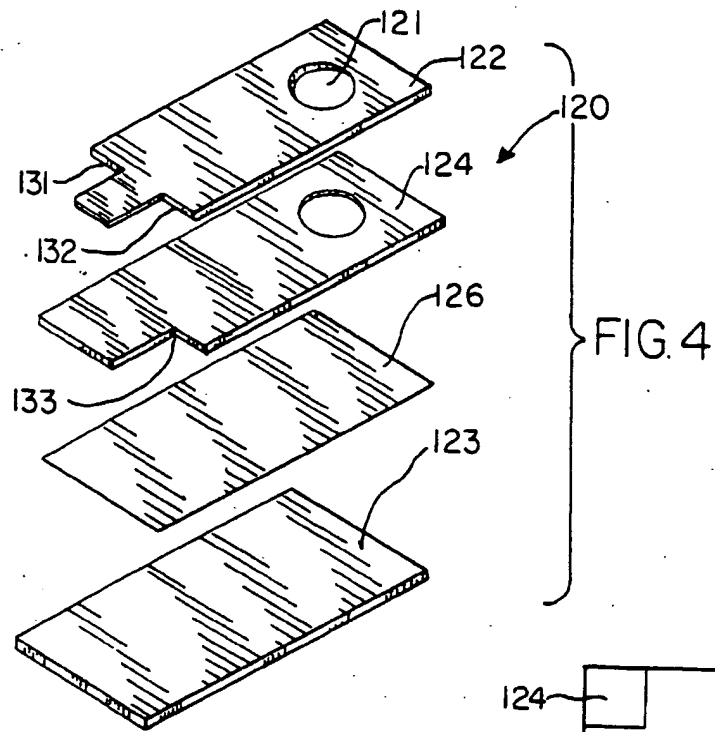
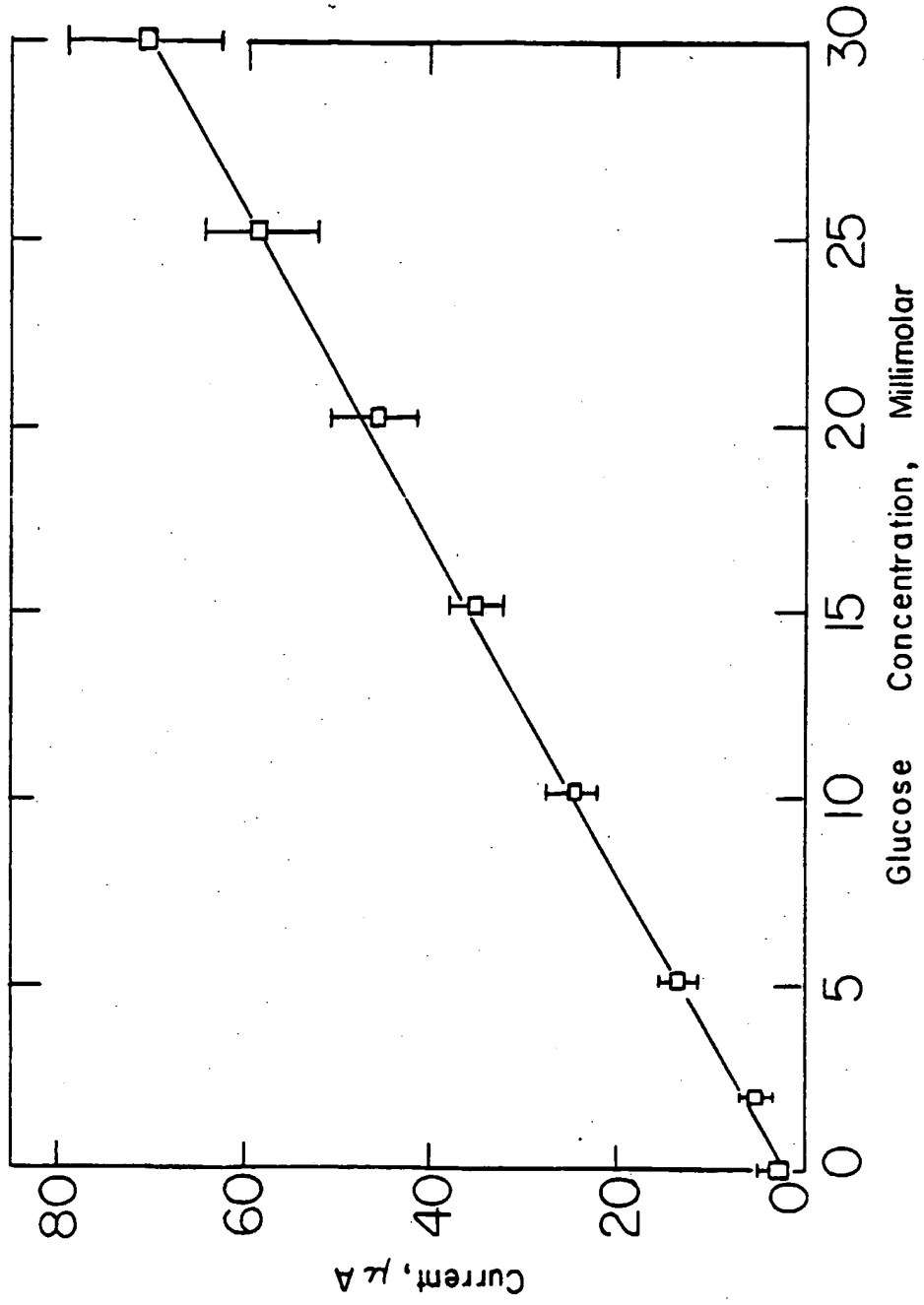

FIG. 7



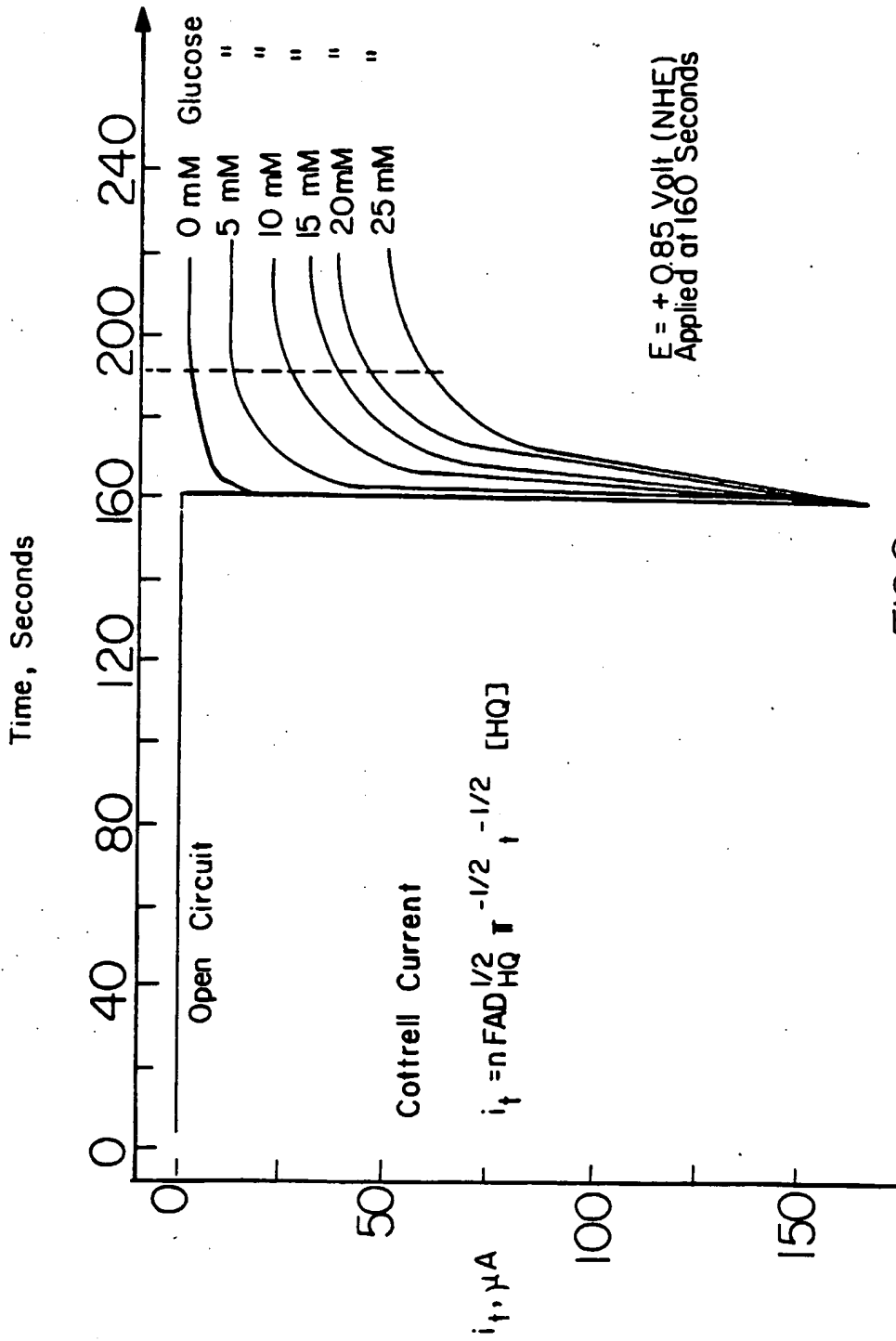

FIG.8

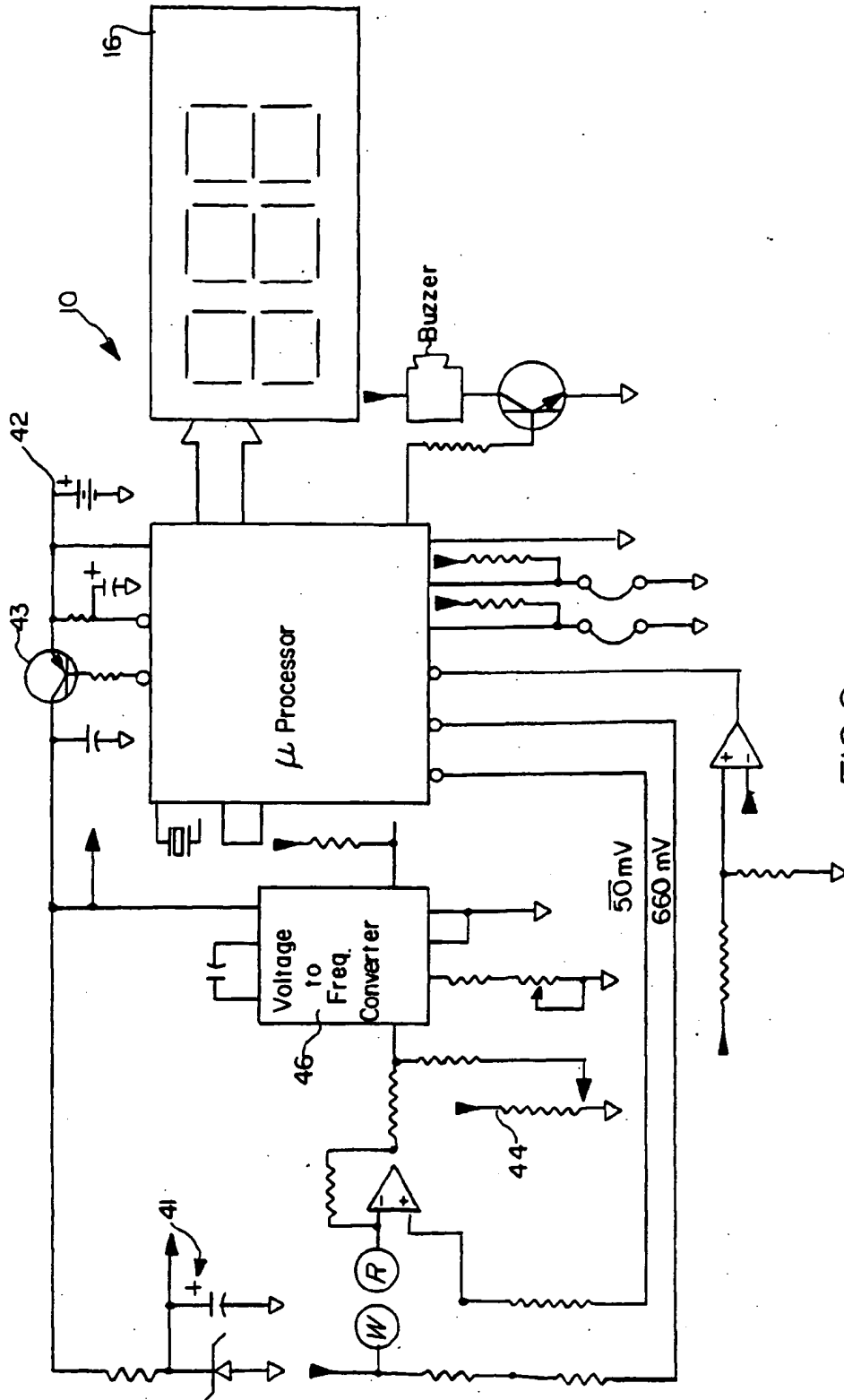

FIG. 9

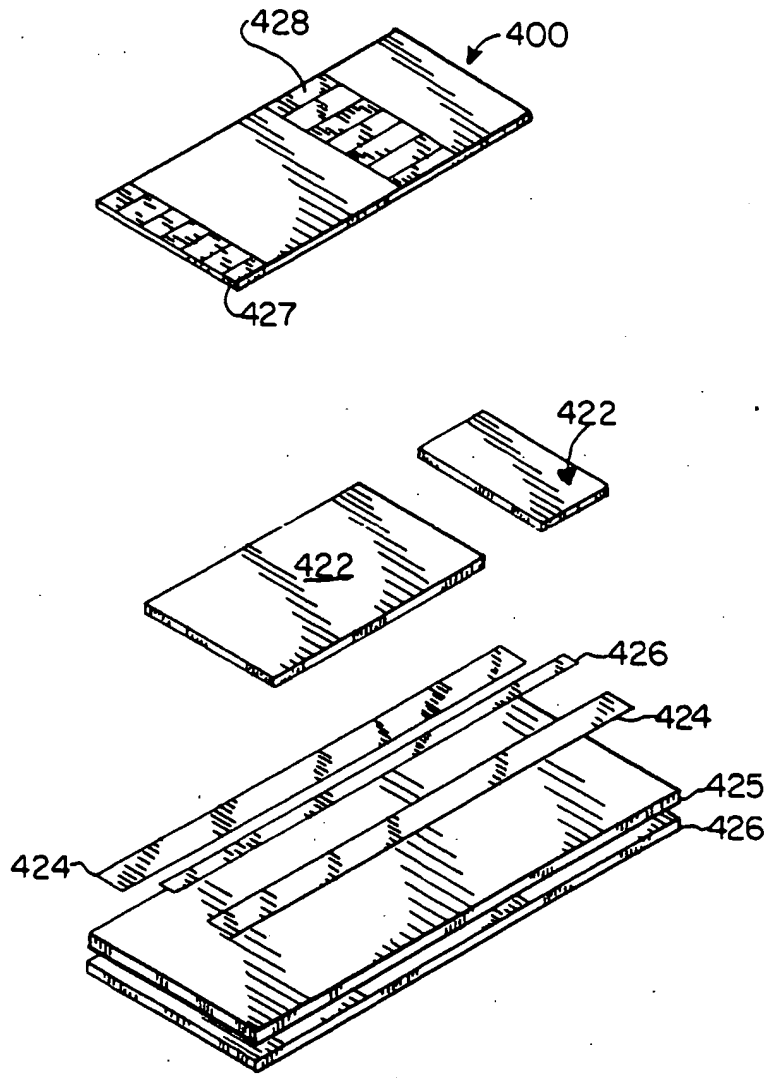

FIG. 10